ETP-1

Elapsed Time Pulser Module

Issue 2 – October 12, 1998
(For METCON-1 and METCON-2)

Tucson Amateur Packet Radio
8987-309 E. Tanque Verde Rd., #337
Tucson, AZ 85749-9399
Phone: +1 940-383-0000
Fax: +1 940-566-2544
tapr@tapr.org

Copyright 1983 — 1998, TAPR. All Rights Reserved.

This document may be reproduced by individuals for their own personal use, provided this notice is included in any reproduction. The information in this document is subject to change without notice and does not represent a commitment on the part of anyone to do anything. No warranty, express or implied, is made regarding this document or associated firmware, or its use or misuse.

1. INTRODUCTION

This paper outlines an Elapsed Time Pulser (ETP) module for use with the METCON telemetry and control system. This module provides a 100 mS pulse output once every N seconds that the input is active, where N can take on integer values from 1 to 498. This module, when connected to a METCON input that is configured as a totalizing pulse counter, provides an elapsed time indicator in units of seconds or minutes.

ETP FUNCTIONS

The ETP's function is simple. When the input is active, a 2 Hz oscillator is enabled to drive a divide-by-1000 decoded counter. The decoded outputs are user selectable so that the user can cause the counters to provide 2 to 999 cycles before being reset. When a reset occurs, it also starts a 100 mS one-shot that drives an opto-isolator output that is connected to METCON.

There are two significant considerations to bear in mind when using ETP regarding the active duration of the TIMER-ON input. To illustrate these considerations consider an ETP configured for one pulse output for every 60 seconds of active input.

The first consideration is the cumulating effect of the TIMER-ON input. If the TIMER-ON is put is active for 20 seconds, then inactive for 5 and then active for another 35 seconds, then inactive for 40 seconds then active for 5 more seconds (total of 60) the output will then pulse to the on state for 100 mS. Thus, ETP accumulates each whole half-second that the input is active and when that totals 60 seconds the output will pulse on and the counters will be reset. ETP measures elapsed time and not just the number of occurrences the input remained continuously active for 60 seconds.

The second consideration is that when the TIMER-ON input is active for only short periods of time (say, less than 3 seconds) a clock synchronization error may be introduced since the input is ANDed with the 2 Hz clock. When the TIMER-ON input is active for short periods of time the actual number of clock cycles recorded by the counters may be more or less than the expected value. For example, consider an extreme

case where the TIMER-ON input is connected to a 100 Hz oscillator. When the internal 2 Hz oscillator's output is low, the counters will not advance because one input to the NAND gate is low. When the internal 2 Hz oscillator's output is high, the counters will advance 25 times. In general, if the TIMER-ON input is typically active for less than 3 seconds, there is a good possibility that the ETP may provide less than desired performance.

CIRCUIT DESCRIPTION.

IC1A, R4, Y1, C7 and C8 form an oscillator at 2^{15} (32,768) Hz. No netting adjustment capacitor is provided for this oscillator as the potential errors that may be caused by slight off-frequency operation are not significant. IC1B and IC1C ensure that the signal is a square-wave. IC1D provides a gate to gate the counter input on/off as determined by the TIMER-ON input.

At the TIMER-ON input R1 provides a 100 K pull down resistance while R2 provides over-voltage protection for IC6A. The TIMER-ON input should be capable of withstanding and performing well with inputs in the range of -50 to +50 VDC. Normally, the TIMER-ON input is active high. Placing a shorting plug on JMP1 makes TIMER-ON active low.

IC2 divides the 32 kHz signal down to a 2 Hz output that drives the decoded counters. IC3, IC4 and IC5 provide decoded counters for units, tens and hundred of half-seconds. The outputs of these counters are cross-connected to D2, D3 and D4 to determine the counter reset value and thus cycle time. The table on the schematic shows what signals should be cross-connected to provide the necessary timer values. When the signals connected to D2, D3 and D4 all go high (or when an input is left open) all three diodes no longer conduct and the input of IC6F (pin 13) will go high because of pull-up resistor R6. IC6F's output will go low causing the voltage at C9 to fall at a rate determined by the values of C9 and R7. C9 is connected to the input of IC6E (a schmitt triggered input). When this input goes sufficiently low, the output (pin 10) will go high and counters will be reset. With the counters reset the diodes will again conduct thus causing the voltage at C9 to rise. The duration of the reset pulse to the counters is determined by the time constant of R7, C9 and the switching characteristics of IC6E. Concurrently with the output of IC6F going low, C10 is discharged through R9 and D5, thus pulling the input to IC6D low. IC6D's output will go high, causing the opto-isolator to conduct. When the counter reset pulse is recognized by the counters IC6F will again go high, thus cutting off D5. The input of IC6D now charges toward +5 volts through R8. When the input of IC6D is sufficiently high its output will go low and the opto-isolator will go inactive. The duration of the pulse from the opto-isolator is determined by the time constant of R8, C10 and the switching characteristics of IC6D.

—————ooOoo—————

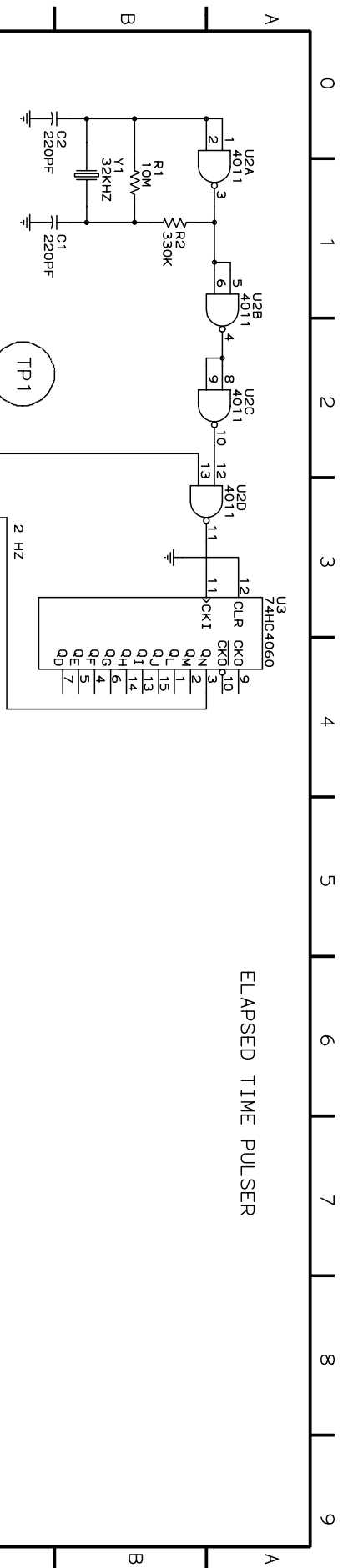

ELAPSED TIME PULSER

JUMPER SETTINGS FOR COMMON TIME INTERVALS

TIME BETWEEN PULSES	PULSES PER MINUTE	CROSS CONNECTS (ALL OTHERS OPEN)
120 SEC	0.5	U5-Y4 U6-Y2
60 SEC	1	U5-Y2 U6-Y1
30 SEC	2	U5-Y6
20 SEC	3	U5-Y4
12 SEC	5	U4-Y4 U5-Y2
10 SEC	6	U5-Y2 U5-Y1
6 SEC	10	U4-Y2 U5-Y1
5 SEC	12	U4-Y4
2 SEC	30	U4-Y4
1 SEC	60	U4-Y2

NOTE: SHORT JP FOR ACTIVE LOW INPUT

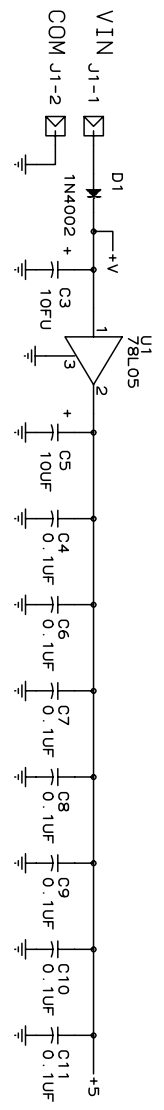
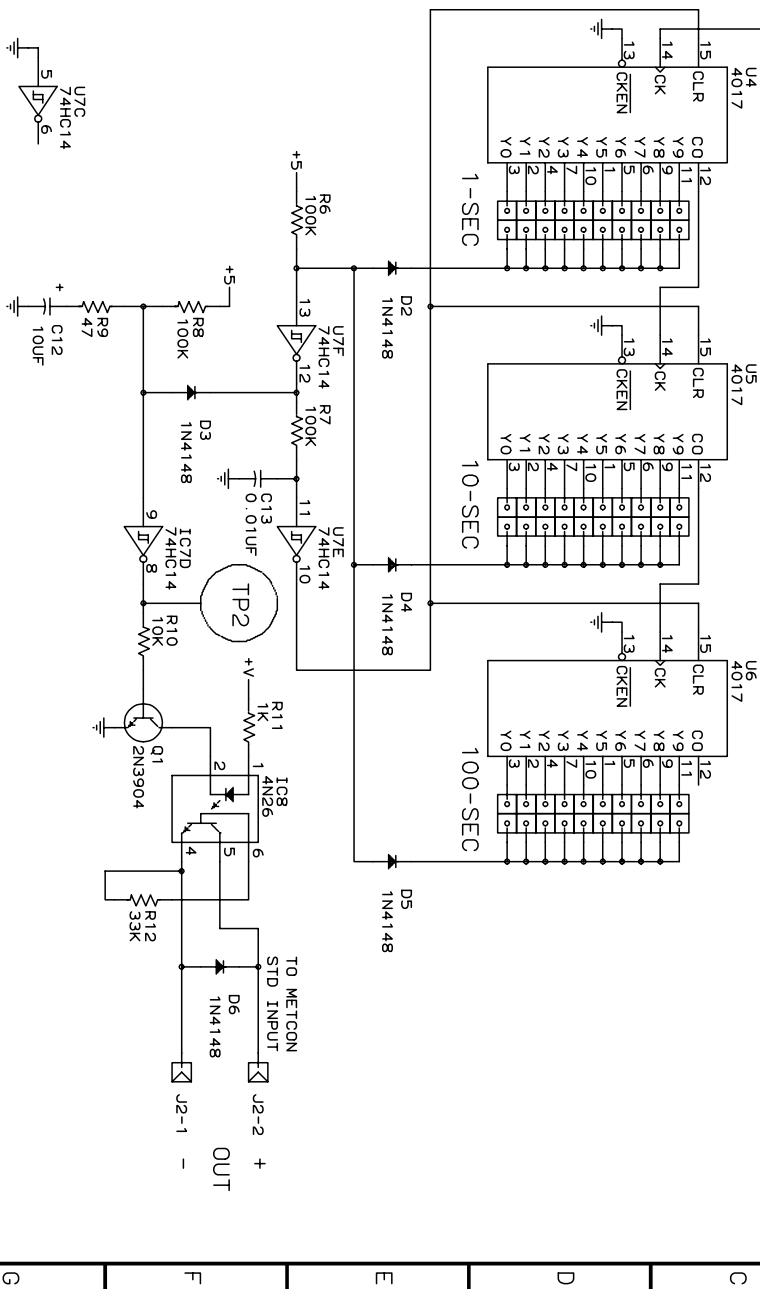

TUCSON AMATEUR PACKET RADIO
 9897-309 E. TANQUE VERDE ROAD, #337
 TUCSON, AZ 85749

METCON ELAPSED TIME PULSER

FILE: MCETP ENGR: PBN REV 0
 ORIG: 920304 LST MOD: 940219 SHT: 1 OF 1